

AL-Cellstacks:
 2 x 3 - 995mm x 200mm x 220mm
 2 x 3 - 995mm x 200mm x 250mm
Adjustment Cellstacks:
 2 x 1 - 995mm x 245mm x 220mm
 2 x 1 - 995mm x 245mm x 250mm
 (Adjustment stacks with double doors:
 1- 995mm x 245mm x 220mm
 1- 995mm x 211mm x 250mm
 1- 995mm x 211mm x 220mm
 1- 995mm x 245mm x 250mm)

Actual components detailed by enclosed specification

Notes:

.....

.....

.....

.....

.....

.....

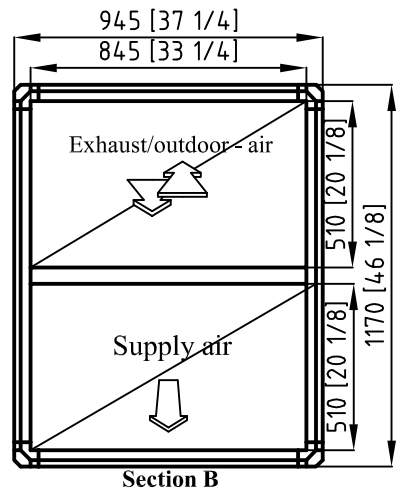
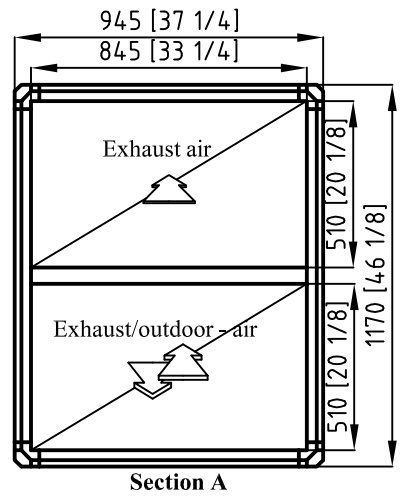

Exhaust filters and cooling/heating coils are available as extras. Extra coils will be placed in a separate unit after the main unit. The unit's dimensions are based on the size of the chosen coil and appropriate inspection plenum.

Drawing subject to change without notice

Tempeff North America Ltd.
 1369 Erin Street, Winnipeg, MB
 Tel:(204) 783-1902, Fax:(204) 633-0496

NOTES:
 (S) SPLIT FOR SHIPMENT

- SERVICE ACCESS PANELS MUST NOT BE OBSTRUCTED RECOMMENDED CLEARANCE = SECTION SIZE.
- DIMENSIONS ARE SUBJECT TO MANUFACTURING TOLERANCES. FOR REFERENCE USE ONLY, SUBJECT TO CHANGE WITHOUT NOTICE

THIS DRAWING IS THE PROPERTY OF TEMPEFF NORTH AMERICA. UNAUTHORIZED USE OR DUPLICATION IS PROHIBITED. USE OTHER THAN INTENDED USE IS PROHIBITED

This unit is also available with optional double doors

| | | | | | |
|-----------------|--------------------|-----------|---------------------------------------|---------------------|----------------|
| Drawn by: RE | Checked by: --- | Rev. A | Under rubrik: Sammanställning | Date: 2002-10-17 | Scale: 1:30 |
| | | | RG 2700 Type 1 with Blowers by others | | |
| | | | 1027 001 BO | | |